

INSTALLATION, OPERATION & MAINTENANCE MANUAL

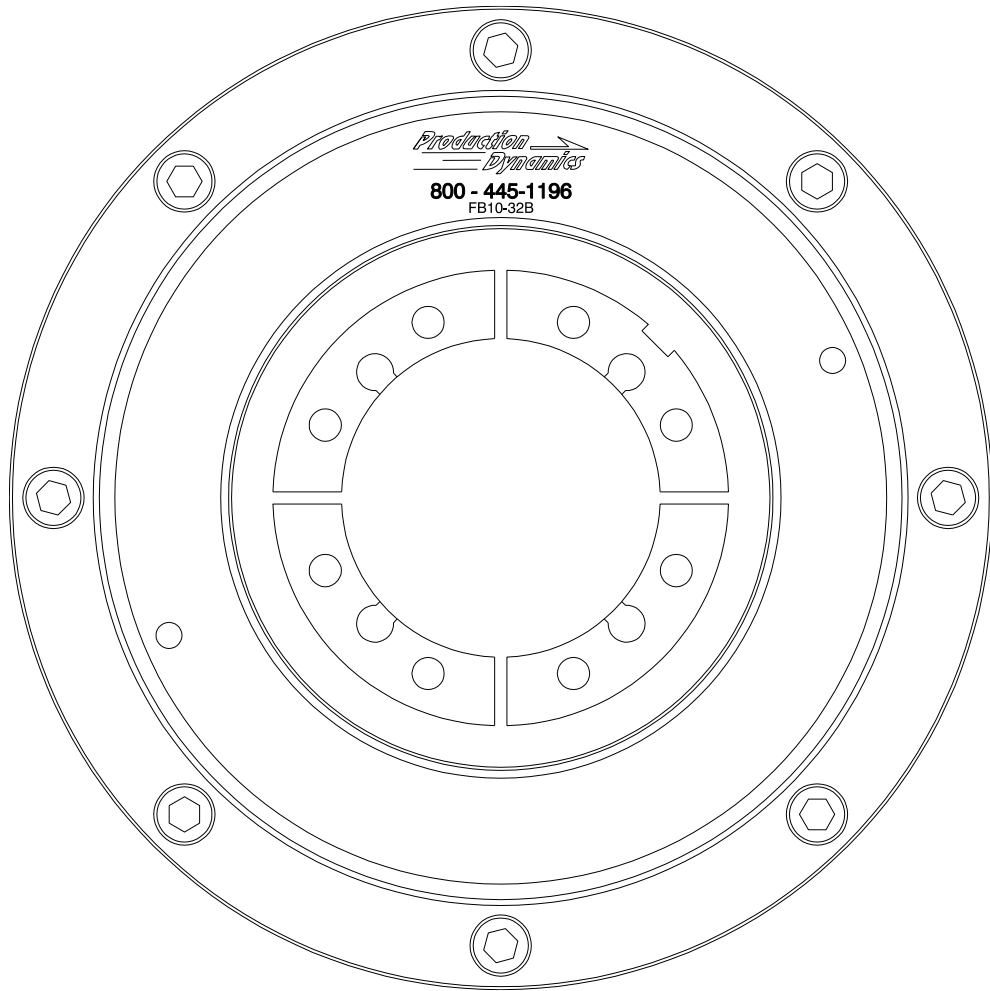

FB10-32B FULL BORE®

MECHANICAL GRIP, AIR RELEASED CHUCK



2025 Mercer Road, Lexington, Kentucky 40511
859-255-5001 • 800-445-1196 • Fax 859-255-6656

www.lexairinc.com

TABLE OF CONTENTS

PART 1	YOUR NEW CHUCK	
	Introduction	2
	Safety Measures	2
	Principles of Operation	5
	Air Supply and Tool Requirements	6
PART 2	INSTALLATION	
	Installation Instructions	7
PART 3	OPERATION	
	Clamping Force	19
	Concentricity	20
PART 4	MAINTENANCE	
	Exploded View of Chuck	21
	Chuck Parts List	22
	Maintenance Instructions	23
	Disassembly of Chuck	25
	Trouble Shooting Guide	26

INTRODUCTION

THANK YOU for selecting a Production Dynamics FULL BORE® Chuck as your new work holding device. Your chuck has been designed and manufactured to provide you with the finest self-contained, mechanical grip collet chuck available today. Properly installed, maintained and operated, your chuck will pay for itself quickly and provide you with years of reliable service.

Before attempting to install or operate your FULL BORE® Chuck, please read this manual. In order to derive the maximum benefit from your chuck and insure that it is properly installed and operated, all supervisors, operators, and maintenance personnel should be trained by experienced individuals familiar with the chuck's operating characteristics and required safety precautions.

In the event that you have a question with your new FULL BORE® Chuck, call our toll free customer assistance hot line at 800-445-1196 to speak to a service technician.

SAFETY MEASURES TO BE OBSERVED

SAFETY ALERT SYMBOL

This is the industry "Safety Alert Symbol." This symbol is used to call your attention to items or operations that could be dangerous to you or other persons using this equipment. Please read these messages and follow these instructions carefully.

It is essential that you read the instructions and safety regulations before you attempt to assemble or use this unit.

MEANING OF SIGNAL WORDS

A safety related message is identified by a safety alert symbol and a signal word to indicate the level of risk involved with a particular hazard. Per ANSI standard Z535.41998 the definitions of the three signal words are as follows:



DANGER indicates an imminently hazardous situation which, if not avoided, will result in death or serious injury.



WARNING indicates a potentially hazardous situation which, if not avoided, will result in death or serious injury.



CAUTION indicates a potentially hazardous situation which, if not avoided, may result in minor or moderate injury.

Before installing or operating your **FULL BORE® Chuck**, please read this manual carefully. Should **ANY** questions develop that affect the operation of the chuck, please call Production Dynamics at **800-445-1196** to speak to a service technician.



DO NOT WEAR GLOVES, TIES, JEWELRY, WATCHES, LOOSE OR ILL FITTING CLOTHING. ALSO LONG HAIR SHOULD BE KEPT OUT OF THE WAY TO PREVENT PERSONAL INJURY AND MACHINE DAMAGE.

⚠ DANGER

TO AVOID PERSONAL INJURY AND MACHINE DAMAGE, NEVER OPERATE THE MACHINE, TOOL, AND CHUCK WHILE UNDER THE INFLUENCE OF ALCOHOL, DRUGS, CONTROLLED SUBSTANCES, OR PRESCRIPTION MEDICINE.

⚠ WARNING

ALWAYS WEAR SAFETY GLASSES.

⚠ WARNING

KEEP HANDS OUT OF THE GRIPPING AREA OF THE CHUCK WHEN GRIPPING A WORKPIECE TO PREVENT PERSONAL INJURY.

⚠ WARNING

DO NOT TOUCH THE CHUCK WHILE THE SPINDLE IS ROTATING TO PREVENT PERSONAL INJURY.

⚠ WARNING

DO NOT MAKE ANY ALTERATIONS, ADD ANY FIXTURES OR CARRY OUT ANY MODIFICATIONS TO THE CHUCK WITHOUT PRIOR AGREEMENT FROM THE MANUFACTURER TO PREVENT MACHINE DAMAGE AND PERSONAL INJURY.

⚠ WARNING

ONLY USE SPARE PARTS WHICH MEET THE REQUIREMENTS OF THE MANUFACTURER TO PREVENT MACHINE DAMAGE AND PERSONAL INJURY.

⚠ WARNING

TURN OFF POWER BEFORE CHANGING, INSPECTING, LUBRICATING, OR SETTING CHUCK TO PREVENT DAMAGE TO MACHINE DAMAGE AND PERSONAL INJURY.

⚠ WARNING

NEVER START MACHINE WITH THE MACHINE DOORS OPEN TO PREVENT PERSONAL INJURY AND MACHINE DAMAGE.

⚠ WARNING

PROPERLY TORQUE THE BOLTS FOR MOUNTING THE CHUCK TO THE SPINDLE. OVER-TORQUE OF THE BOLTS MAY CAUSE CRACKS AND UNDER-TORQUE MAY ALLOW THE BOLTS TO BE LOOSE. NOT COMPLYING WITH THE TORQUE SPECIFICATIONS MAY CAUSE MACHINE DAMAGE AND PERSONAL INJURY.

⚠ WARNING

LONG WORKPIECES REQUIRE THE USE OF A TAILSTOCK CENTER OR A STEADY REST. WORKPIECES ARE CONSIDERED LONG WHEN THE LENGTH IS APPROXIMATELY THREE (3) TIMES THE DIAMETER. THIS APPLIES ONLY IF THE PART IS GRIPPED BY THE COMPLETE LENGTH OF THE PAD. THE WORKPIECE MAY COME OUT OF THE PADS CAUSING PERSONAL INJURY AND MACHINE DAMAGE.

▲WARNING

HEAVY CUTS AT HIGH RPM'S CAN CAUSE THE WORKPIECE TO SLIP AND/OR COME LOOSE CAUSING MACHINE DAMAGE AND PERSONAL INJURY.

▲WARNING

DO NOT MODIFY THE CHUCK. ANY MODIFICATION MAY CAUSE THE CHUCK TO FAIL CAUSING DAMAGE TO THE MACHINE AND PERSONAL INJURY.

▲WARNING

NEVER HAMMER THE CHUCK PADS, OR WORKPIECE TO PREVENT DAMAGE TO THE MACHINE AND PERSONAL INJURY.

▲WARNING

AFTER ANY COLLISION THE COLLET AND THE CHUCK MUST BE REMOVED AND CHECKED FOR ANY CRACKS, IMBALANCE, OR DAMAGE. THE CHUCK MUST NOT BE USED UNLESS CERTIFIED BY A PERSON WITH PROPER CREDENTIALS TO PREVENT PERSONAL INJURY AND DAMAGE.

▲WARNING

REPLACE DAMAGED BOLTS AFTER A COLLISION. BOLTS HOLDING THE FACEPLATE TO THE CHUCK BODY AND/OR USED TO MOUNT THE CHUCK MUST BE REPLACED WITH BOLTS APPROVED BY THE MANUFACTURER TO PREVENT MACHINE DAMAGE AND PERSONAL INJURY.

▲CAUTION

WHEN OPERATING PRODUCTION EQUIPMENT OF ANY KIND, GENERAL SHOP SAFETY MEASURES SHOULD ALWAYS BE OBSERVED. FOLLOWING THE OPERATING INSTRUCTIONS, USING GOOD SHOP SAFETY PRACTICES WILL PREVENT MACHINE DAMAGE AND PERSONAL INJURY.

▲CAUTION

BEFORE INSTALLING OR OPERATING YOUR FULL BORE® CHUCK, PLEASE READ THIS MANUAL CAREFULLY AND GET ALL OF YOUR QUESTIONS ANSWERED.

▲CAUTION

WHEN LIFTING THE CHUCK USE THE EYEBOLT AND A HOIST. FOR CHUCKS THAT DO NOT HAVE ANY EYEBOLT, USE A LIFTING STRAP OF SUFFICIENT CAPACITY AND A HOIST TO PREVENT PERSONAL INJURY AND MACHINE DAMAGE.

▲CAUTION

DO NOT OPEN THE CHUCK WHILE THE SPINDLE IS ROTATING. THIS WILL CAUSE SEVERE DAMAGE TO THE GLAND AND TO THE BACK OF THE CHUCK. MACHINE DAMAGE AND PERSONAL INJURY CAN RESULT.

PRINCIPLES OF OPERATION

The **Production Dynamics FULL BORE® Chuck** is a self contained, mechanical grip, air release front-mounted collet chuck. The chuck does not require an external actuator since the actuator is built into the chuck. Air is used only to OPEN the chuck. Spring force holds the workpiece while it is being machined. Thus, the part remains clamped, even if air pressure is lost. Higher spindle speeds can be used because a collet chuck does not have heavy jaws that lose grip force as the spindle speed of the machine increases. Clamping force is adjustable by tightening or loosening the collet, using the spanner wrench holes in front of the collet. Removing pairs of springs inside the chuck can also reduce the clamp force. Because the chuck does not use a drawtube, more spindle area is available.

The gland and gland housing assembly are used to transmit the air to the chuck. When the spindle is stopped, and the chuck is opened, the air valve allows air into the gland housing, pushing the gland forward against the back of the chuck. The face of the gland seals against the chuck, and allows air pressure to build inside the chuck, moving the piston forward. The rollers drop back, allowing the pusher to move back and release the collet. The piston compresses the grip force die-springs. Small return die-springs move the pusher back releasing the collet.

When the chuck is closed, the air to the gland housing is vented to atmosphere, the gland retracts from the chuck body, and the springs and wedging action of the piston, ramp, rollers and pusher close the collet on the part.

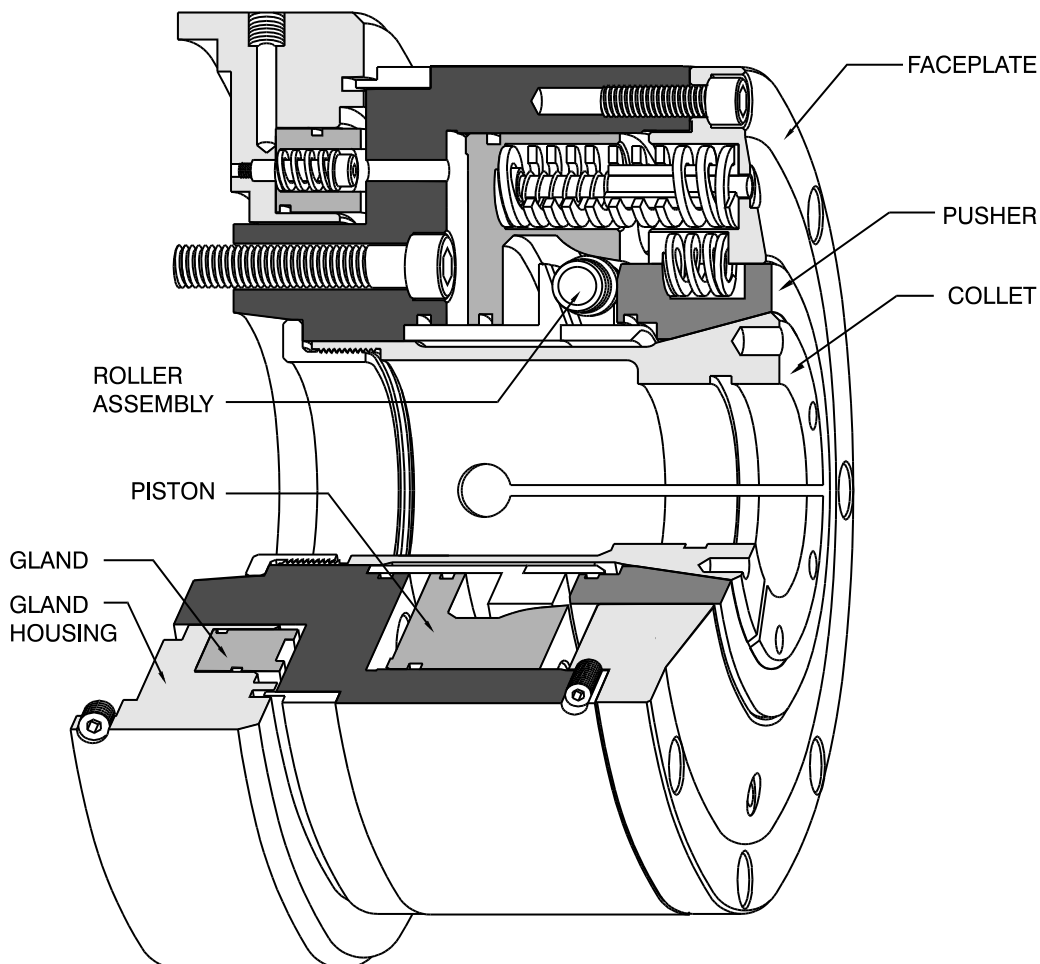

AIR SUPPLY AND TOOL REQUIREMENTS

AIR SUPPLY REQUIREMENTS	TOOLS REQUIRED FOR INSTALLATION
<ol style="list-style-type: none"> 1. Dedicated air line <u>for chuck only</u> from shop air supply 2. ½" i.d. hard piped air line to filter 3. <u>No</u> reduced air fittings or air lines 4. <u>100</u> psi minimum shop air 5. 15-22 cfm shop air 6. Keep air line oil in oiler and set drip rate to one drip per cycle 	<ol style="list-style-type: none"> 1. Metric and English allen wrenches 2. 12" crescent wrench 3. Screw drivers 4. Wire strippers 5. Wire ties 6. 3/8" drive drill 7. 6" dial calipers 8. Test indicator and base 9. Hole punch

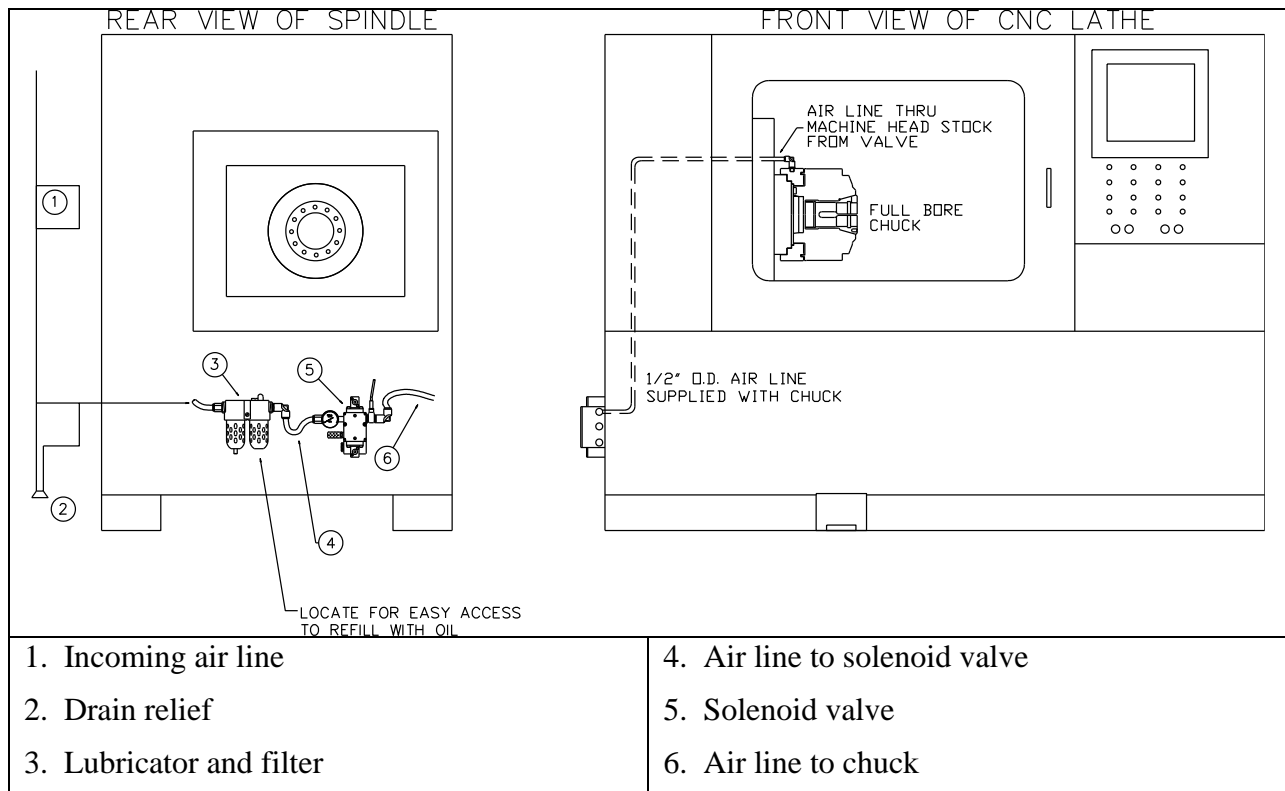

INSTALLATION INSTRUCTIONS

Your new **FULL BORE® Chuck** has been designed and manufactured to provide years of reliable service. The following guide will aid you in the installation of your chuck. Please read this manual thoroughly first, to be familiar with the installation of the chuck.

⚠ DANGER

TO AVOID PERSONAL INJURY AND MACHINE DAMAGE, TURN OFF THE MAIN ELECTRICAL POWER TO THE MACHINE BEFORE STARTING THE INSTALLATION.

⚠ DANGER

TO AVOID PERSONAL INJURY AND MACHINE DAMAGE, TURN OFF THE AIR SUPPLY TO THE MACHINE.

⚠ CAUTION

ONE PERSON SHOULD NOT ATTEMPT THE LIFTING OF THE CHUCK FROM ITS PACKAGING. WHEN LIFTING THE CHUCK, USE THE EYEBOLT AND A HOIST. FOR CHUCKS THAT DO NOT HAVE AN EYEBOLT, USE A LIFTING STRAP OF SUFFICIENT CAPACITY AND A HOIST TO PREVENT PERSONAL INJURY AND DAMAGE TO THE MACHINE.

⚠ CAUTION

PARTIAL DISASSEMBLY OF THE CHUCK IS REQUIRED FOR INSTALLATION. THE PUSHER AND FACEPLATE SHOULD NOT BE SEPARATED WHEN DISASSEMBLING A NEW CHUCK. HOWEVER, IF SEPARATED, EXERCISE GREAT CARE IN REASSEMBLING, SINCE THE FIT OF THESE TWO COMPONENTS IS CRITICAL TO THE FUNCTION OF THE CHUCK.



⚠ CAUTION

FORCING THE PUSHER AND FACEPLATE TOGETHER MAY CAUSE COMPONENT DAMAGE OR PERSONAL INJURY. THE TWO COMPONENTS WILL EASILY SLIDE TOGETHER WITH CAREFUL ALIGNMENT AND GENTLE TAPPING WITH A SOFT OBJECT.



The gland and gland housing do not need to be separated for installation. The gland has o-ring seals that will require replacement in time. Replacement of these o-rings is covered in the maintenance portion of this manual. (Gland housing may vary according to installation requirements).

Begin disassembly of the chuck by removing the collet. Set the chuck on its side and hold on to the puller as you unthread the collet. Set the puller off to the side with the collet. Remove six of the eight bolts in the faceplate, leaving two bolts 180° apart. Loosen the remaining two bolts, about two turns at a time. These bolts will release the tension of the springs inside the chuck. **ALL** of the spring tension will be released before the bolts are unthreaded. After all the bolts are removed, the faceplate and pusher can be carefully lifted off the chuck together.



TO AVOID MACHINE DAMAGE OR PERSONAL INJURY, MAKE SURE THE PUSHER DOES NOT FALL OUT OF THE FACEPLATE.



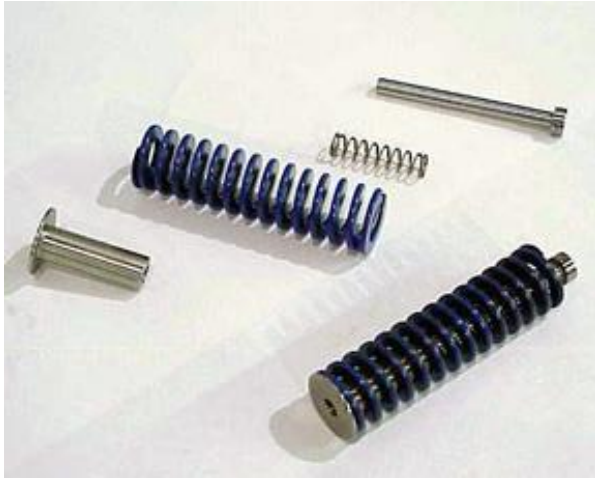

Remove the springs from the piston.

NOTE: Pay attention to the location of the indicator pin assemblies. These assemblies must be aligned with the holes in the faceplate when installed. This will allow the pins to protrude through the faceplate of the reassembled chuck when it is in the unchucked position.

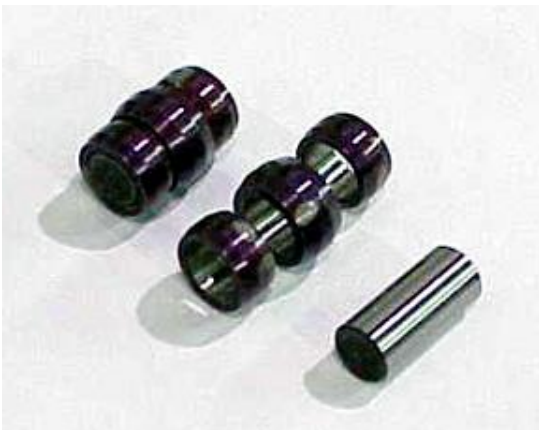

Remove the roller and axle assemblies and set on a clean surface until re-assembly.

Using the aluminum handle provided, remove the piston by installing two 1/4-20 x 2-1/2" long bolts through the holes in the handle and into the two threaded holes in the face of the piston and pulling gently by hand.





Remove the 1/4-20 x 2-1/2" screws from the piston. Remove the ramp from the piston.

GLAND HOUSING CLEARANCE

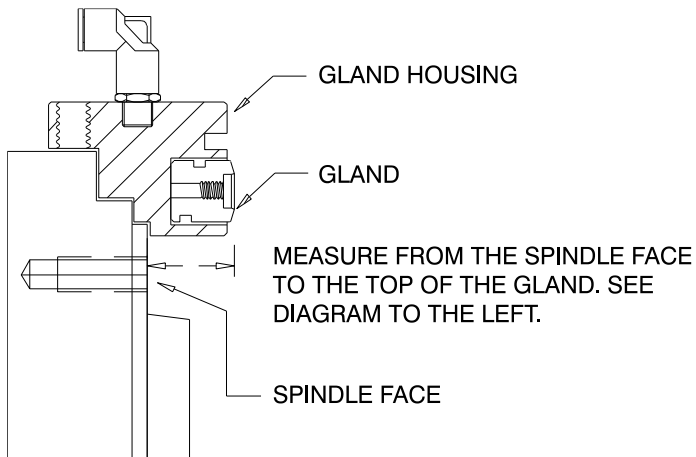

While putting on the Gland Housing, be sure to measure for clearance between the chuck and Gland Housing. This distance should be .030" to .040" less than the length from the back of the chuck to where the gland seals. See Illustration below. This will allow clearance for the chuck to rotate freely.

For the FB10-32B the distance from the back of the chuck to where the gland seals is 1.50 inches. So the distance from the spindle face to the top of the gland should be 1.46" to 1.47".

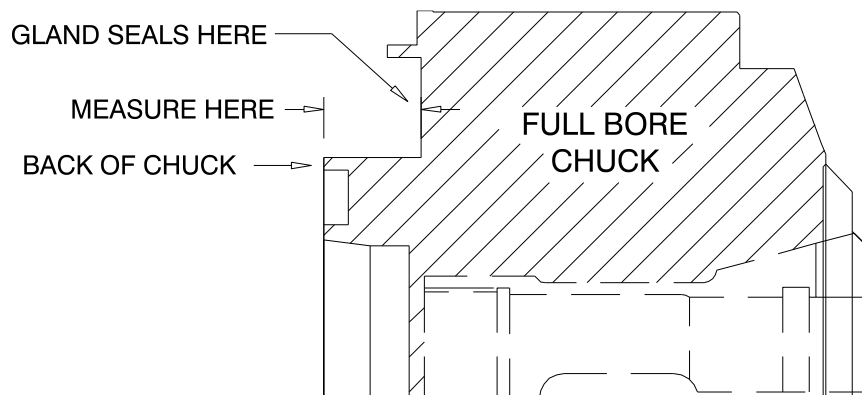

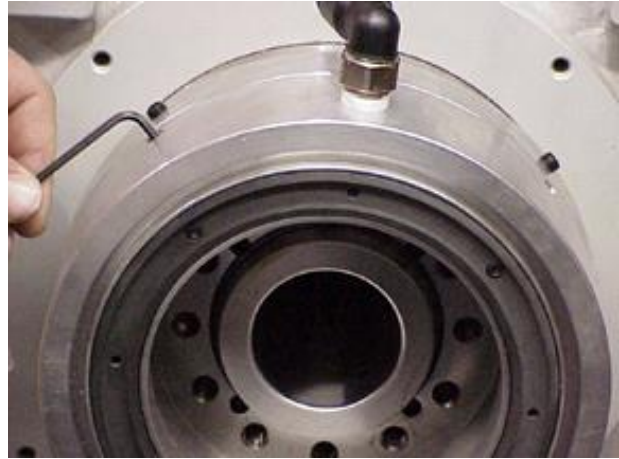

Mount the gland and gland housing assembly on the spindle bearing housing as shown, with the air fitting in the gland housing on top and the coolant drain at the bottom. Snug the set screws on the outside diameter of the housing. If there is no provision for an air line, one must be made at a location where there will be no interference with sliding covers, electrical connections, or the tool eye. Remove the gland housing from the lathe. Use a chassis punch to create a hole that is at least ½” in diameter. Deburr the hole, and use a grommet in the hole to prevent cutting the airline. Remount the gland housing on the spindle cap, and snug the set screws.

The **FULL BORE® Chuck** Installation Kit contains the necessary air valve, lubricator, filter, fitting, air line tubing, and wire to install the chuck on most machines. The air valve can be mounted in a horizontal or vertical position, but the lubricator/filter must be mounted vertically at a location where the machine operator can check and service the unit easily.

⚠ DANGER **TURN OFF THE MAIN ELECTRICAL POWER TO THE LATHE TO PREVENT DAMAGE TO THE MACHINE AND ELECTRICAL SHOCK WHICH COULD CAUSE INJURY OR DEATH.**

⚠ WARNING **A QUALIFIED ELECTRICIAN SHOULD PERFORM ELECTRICAL INTERFACE.**

Loosen the two fillister head screws and remove the junction box cover on the bottom of the valve near the conduit connection. Pull all five wires into the junction box so that they come out the bottom of the valve. Strip approximately four inches of the outer rubber jacket off the power cord.

⚠ WARNING **BE CAREFUL NOT TO NICK THE INSULATION ON THE WIRES TO PREVENT MACHINE DAMAGE AND AN ELECTRICAL SHOCK HAZARD.**

Screw one cord grip (VE0020) into the conduit connection on the valve. Insert the stripped end of the wire through the cord grip and tighten. Make sure the cord is held securely. Strip all nine wires back approximately 3/8 of an inch.



BE CAREFUL NOT TO NICK THE COPPER WIRE TO PREVENT MACHINE DAMAGE AND AN ELECTRICAL SHOCK HAZARD.

Make connections as follows:

	<p><u>Wires from Power Cord Wires from Valve</u></p> <p>Green.....Green/yellow stripe White.....1 yellow and 1 red Red.....Other red Black.....Other yellow</p> <p>Screw on wire nuts and tape with electrical tape. Tuck all wires carefully into junction box and replace cover.</p>
--	-----------------------------------------------------------------------------------------------------------------------------------------------------------------------------------------------------------------------------------------------------------------------------------------------------------------

Mount the air valve near the electrical junction panel on a rigid member of the machine that will not interfere with sliding doors and panels. Use the 1/4-20 x 1-1/2" socket head cap screws and 1/4-20 nuts supplied with the kit. Mount filter/lubricator assembly in an accessible location for regular maintenance using mounting bracket and 1/4-20x3/4 socket head cap screws and 1/4-20 nuts supplied with kit. (See piping or air requirement diagram). Connect air line from lubricator to valve (air fitting by gage) using air line supplied in kit. Make sure the lubricator is in an accessible location for regular maintenance. With the air supply to the machine turned off, connect the shop air (100 psi, at least 1/2" line and 10-15 cfm) to the air valve.



TO PREVENT AIR FROM DISCHARGING IN AN UNCONTROLLED MANNER, DO NOT TURN THE AIR ON AT THIS TIME. PERSONAL INJURY OR MACHINE DAMAGE MAY OCCUR.



If necessary wire the confirmation switch into the machine according to the electrical diagram supplied with the machine.

Look at the manufacturer's wiring diagram. The chuck control circuits should look something like those shown below. Make sure the control circuit voltage matches the voltage printed on the air valve. Most lathes use 24VDC or 100 VAC to control the chuck solenoid.

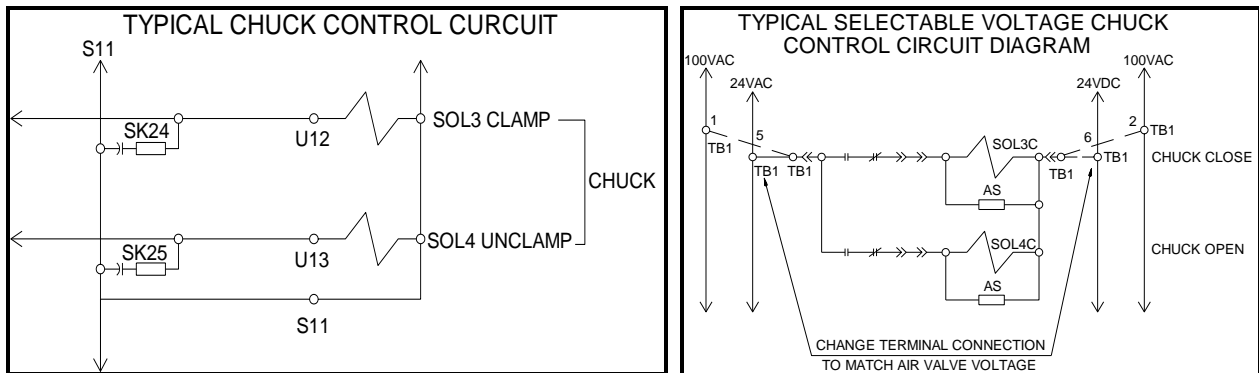

Locate the terminal strip in the electrical cabinet that has the connections for the Chuck Open and Chuck Close solenoids. Locate an area on the electrical cabinet near this terminal strip for the air valves' power cord to enter the cabinet. Drill a pilot hole and use a 1/2 chassis punch to punch out a hole for the cord grip.



TO PREVENT PERSONAL INJURY AND MACHINE DAMAGE, MAKE SURE THE DRILL WILL NOT HIT ANYTHING ON THE INSIDE OF THE CABINET PRIOR TO DRILLING. USE EYE PROTECTION TO KEEP METAL CHIPS FROM INJURING EYES.

Insert the cord grip into the punched hole and secure in place with the sealing lock nut provided. Push the power cord through the cord grip and tighten, making sure the cord is held firmly. Determine how much wire is needed in the cabinet and cut off any excess. Strip off the rubber jacket as needed.



BE CAREFUL NOT TO NICK THE INSULATION ON THE WIRES TO PREVENT MACHINE DAMAGE AND AN ELECTRICAL SHOCK HAZARD.

Strip the insulation off the wires approximately 1/4 inch and crimp on the terminals supplied with the installation kit.

Connect the air valve in parallel with the chuck open and chuck close solenoids as shown below in the general diagram.

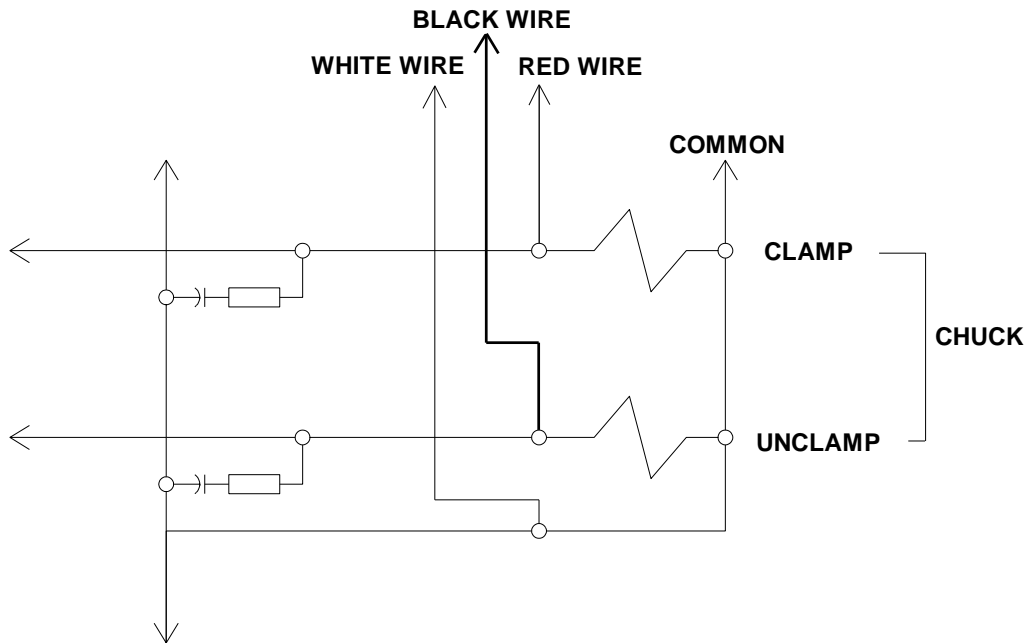

Connect the **WHITE** wire to the **COMMON** side of the solenoids
Connect the **BLACK** wire to the **OPEN** signal
Connect the **RED** wire to the **CLOSE** signal
Connect the **GREEN** wire to **EARTH** Ground

Use cable ties to secure wires and cord in a neat and orderly fashion.

Turn on the electrical power to the lathe.

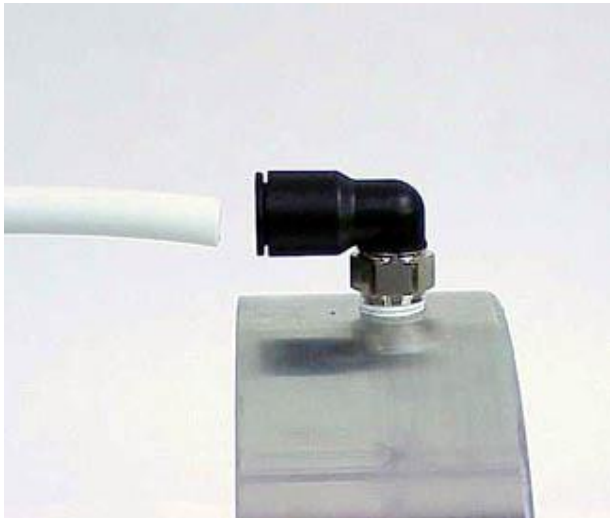

Connect air supply from the valve to the gland housing using the 1/2" airline supplied in the kit. The port in the gland housing is tapped 3/8 – 18 NPT. Cut off any excess airline and tie up loose or drooping line with wire ties.

⚠ DANGER

DO NOT TURN THE AIR ON UNTIL THE CHUCK BODY HAS BEEN INSTALLED TO PREVENT PERSONAL INJURY AND DAMAGE TO THE GLAND, O'RINGS, AND MACHINE.

⚠WARNING

WHEN LIFTING THE CHUCK, USE THE EYEBOLT AND A HOIST. FOR CHUCKS THAT DO NOT HAVE ANY EYEBOLT, USE A LIFTING STRAP OF SUFFICIENT CAPACITY AND A HOIST. WHEN INSTALLING THE CHUCK BODY, IT IS HELPFUL TO HAVE ONE PERSON STEADY THE BODY ON THE SPINDLE AND THE OTHER TIGHTEN THE BOLTS THAT MOUNT THE BODY TO THE SPINDLE.

⚠CAUTION

TO PREVENT THE NEED TO REPEAT THE ASSEMBLY PROCESS, DO NOT FORGET TO PLACE THE PULLER IN THE BACK OF THE CHUCK BODY. MAKE SURE THE PIN FITS IN THE SLOT ON THE FLANGE OF THE PULLER. HOLD PULLER IN PLACE UNTIL CHUCK BODY IS MOUNTED ON THE SPINDLE.



With the puller in place on the spindle side of the chuck body, mount the chuck body on the spindle, making sure the drive button in the spindle lines up with the counterbore in the back of the chuck body. Screw in the six bolts that hold the chuck body to the spindle. Alternate between opposite bolts while tightening. Put the machine in the spindle lock if equipped, or lowest gear to prevent the spindle from rotating. Two of the faceplate mount bolts can be screwed into the face of the chuck, and a bar can be placed between these for leverage.

With the body installed and mounting bolts tight, reach into the body and make sure the puller is free to move. There will be a little side to side motion.

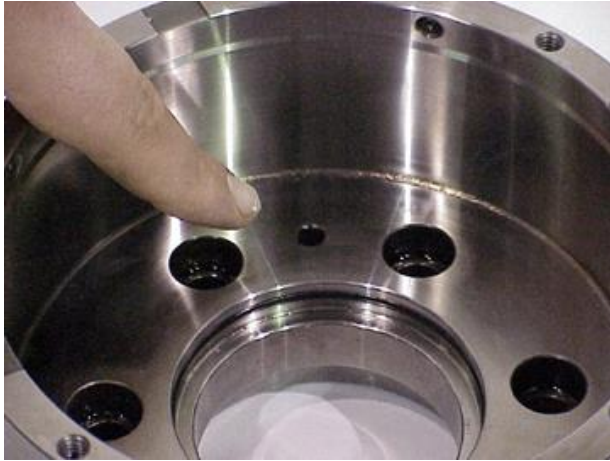

The gland can now be tested for operation and leaks at this point. Turn on the air supply to the valve. Use the foot pedal or chuck open/close switch to open the chuck. Air will blow out the feed holes in the inside of the chuck. There should **NOT** be air leaking from around the body/gland housing interface. With the air off, and the spindle in high gear, the spindle should rotate easily.

⚠ DANGER

TURN OFF THE AIR SUPPLY AGAIN TO PREVENT MACHINE DAMAGE AND PERSONAL INJURY.

⚠ WARNING

PRODUCTION DYNAMICS RECOMMENDS LUBRIPLATE No. 1444 GREASE, PRODUCTION DYNAMICS PART No. VM0012. FAILURE TO USE THIS LUBRICATION MAY CAUSE EXCESSIVE WEAR TO MOVING COMPONENTS AND/OR RESULT IN CHUCK FAILURE.



Apply a light coat of grease to both o-rings on the piston and to the I.D. of the body. Gently slide the piston into the chuck body taking care not to wedge the piston in the body.

Push it back until it stops against the back of the chuck body. Grease the I.D. o-ring in the body.

Apply a light coat of grease to the rear outside diameter of the ramp. Gently insert the ramp into the piston, until it stops firmly against the shoulder in the body.



Install the roller and axle assemblies into the ramp. **LIGHTLY** grease the assembly to hold them in place for installation, and for lubrication after assembly.



Install the springs into the piston pockets. The springs contain the indicator pin assemblies. (See NOTE and photo on page 9 for a view of indicator pin assembly). They must be installed and aligned with the holes in the faceplate to assure proper chuck operation.



FAILURE TO INSTALL THE INDICATOR PIN ASSEMBLIES IN LINE WITH THE HOLES IN THE FACEPLATE MAY CAUSE DAMAGE TO THE PINS AND THE CHUCK DURING FACEPLATE INSTALLATION.



Install the faceplate/pusher combination on the chuck, making sure the indicator pins line up with the holes in the faceplate. Twist the faceplate/pusher combination while on the chuck so the bolt holes in the faceplate line up with the threaded holes in the chuck body.

Start the 8 bolts in the faceplate until finger tight. Tighten two opposite bolts about two turns at a time. This will keep the faceplate from wedging in the bore of the chuck body. Four bolts at 90° can be used if preferred, tightening in rotation. Tighten all bolts at this time.

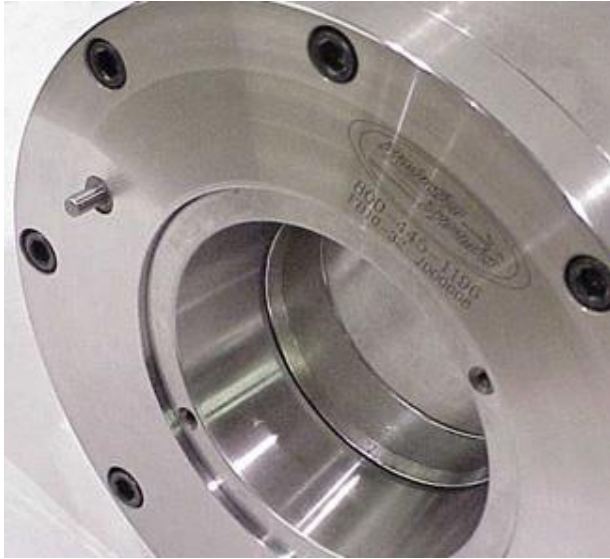

Turn on the air supply to the lathe. The assembled chuck can now be actuated. The pusher will retract when the chuck is opened, or un-chucked, and will move forward when opened, or chucked. Notice the indicator pins moving in and out while the chuck is closed and opened, respectively.

Install the collet with the chuck in the open, or un-chucked position, by screwing the collet into the chuck as shown. Install the collet pads in the collet. Chuck on a piece of bar stock that is the same size as the pads. Loosen and retighten the pads in the collet while clamped on the workpiece, so that the pads seat themselves in the collet. Adjust the clamping force by screwing the collet into the chuck. Screw the collet into the chuck with the chuck in the open position. Close the chuck to see if the indicator pins are flush with the counterbores in the faceplate. Light clamping force is achieved when the indicator pins are below flush, with the greatest clamp force having the indicator pins flush with the counterbores. Refer to the “**OPERATION**” portion of this manual for a further discussion on clamp force.

▲ DANGER TO AVOID DAMAGE AND PERSONAL INJURY, NEVER OPERATE THE CHUCK WITH THE INDICATOR PINS ABOVE THE FLUSH POSITION.

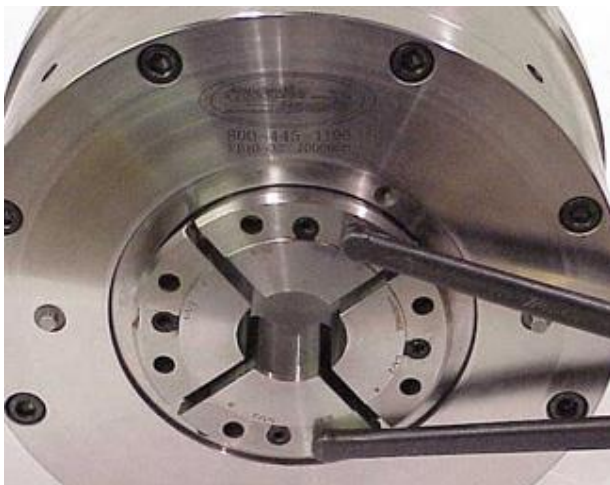

The chuck may release the workpiece due to low grip force. With the pins above flush, the collet grip force drops significantly. Remember, when the pins are extended out all the way, the collet is open and the workpiece is released.

With the chuck in the open position, loosen all 4 gland housing set screws ½ turn then snug back up again to assure the gland housing is seated against the bearing cap.

OPERATION

This portion of the manual is written to enable you to get the most out of your new **FULL BORE® Chuck** and become familiar with its operations.

CAUTION TO PREVENT PERSONAL INJURY AND MACHINE DAMAGE, PLEASE CAREFULLY READ AND FOLLOW THESE INSTRUCTIONS BEFORE OPERATING THE CHUCK!

CLAMPING FORCE



Clamping force or grip force is adjusted by screwing the collet in or out of the chuck. Grip force is increased by the clockwise rotation of the collet. Maximum clamping force is achieved when the indicator pins are flush with the counterbores in the faceplate. To reduce the grip force, rotate the collet counterclockwise until the desired grip is attained. With the force less than maximum, the indicator pins will sit at a position below flush with the counterbores.

Always tighten or loosen the collet with the chuck in the open position. Grip force can only be determined with the chuck closed with air OFF.

Clamp the chuck to observe the position of the pins. Open the chuck and tighten or loosen the collet until the desired clamp force is achieved.

DANGER NEVER OPERATE THE CHUCK WITH THE INDICATOR PINS ABOVE FLUSH TO PREVENT MACHINE DAMAGE AND PERSONAL INJURY.

With the chuck closed and the indicator pins above flush, the clamp force drops significantly. With the chuck in the open position, the indicator pins are visible. Thus, when the indicator pins are protruding from the faceplate, the collet is open and the workpiece is free to move.

CAUTION NEVER OPEN THE CHUCK FOR MORE THAN 10 SECONDS AT MORE THAN 500 RPM WHILE THE SPINDLE IS ROTATING! THIS WILL DAMAGE THE SEALS IN THE GLAND AND CAN DAMAGE THE CHUCK AND MACHINE, AND CAUSE PERSONAL INJURY.

CONCENTRICITY

The faceplate of the chuck can be “zeroed in” for concentricity. The procedure is similar to indicating a workpiece in a 4-jaw chuck. This is done by loosening the faceplate bolts slightly, and tightening or loosening the four setscrews near the front of the chuck. Place an indicator on the workpiece, and adjust the four setscrews. Tighten the bolts in the faceplate.

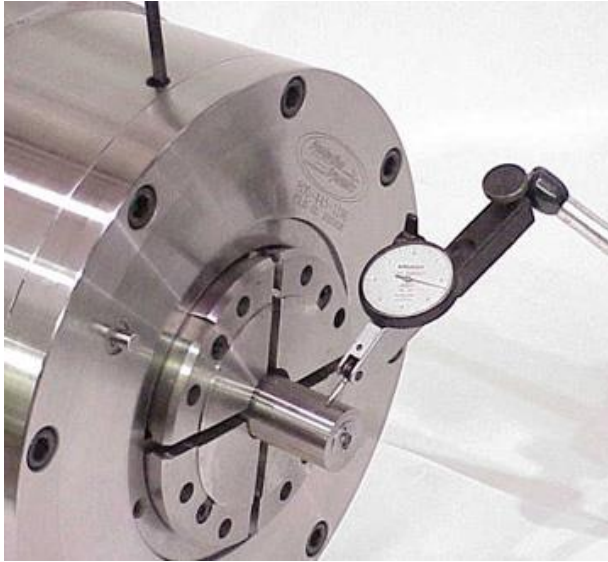

For high precision work, indicate the faceplate in using a piece of ground stock held in the collet pads. This procedure should be performed each time the collet or pads are replaced, if the accuracy requirements justify it.

It is important to note that the setscrews are only for zeroing the workpiece and faceplate. After the workpiece is indicated to the desired concentricity, tighten the eight faceplate bolts.

⚠ WARNING

THE SETSCREWS MUST BE BACKED OFF UNTIL SNUG, NOT TIGHT. WHEN TIGHT, THE SETSCREWS MAY BIND THE PUSHER IN THE FACEPLATE AND THE CHUCK WILL NOT OPEN.

Maintenance

NUMBERS OUTLINED WITH A HEXAGON SIGNIFY DIFFERENCE BETWEEN NEW AND OLD BODY STYLE. SEE PARTS LIST.

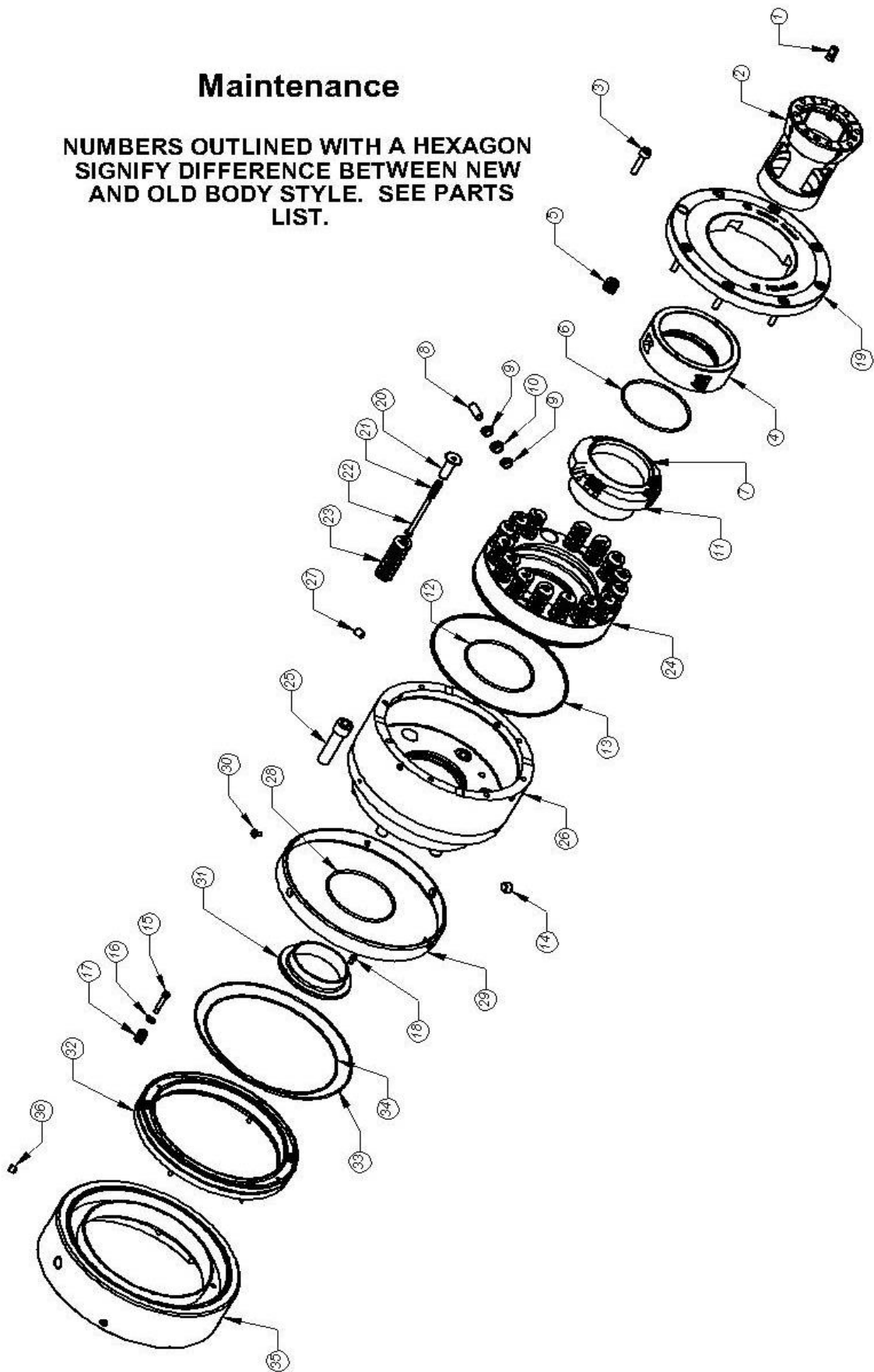

Part Number List for FB10-32B FULL BORE® Chuck

DESCRIPTION	PART NUMBER	QTY
1. Collet Pad Clamp	PS CLAMP-C	4
2. Hardinge Master Collet	J610	1
3. 3/8-16x 1-1/4 SHC Screw	VT37-16SH1.2	8
4. Pusher	J570	1
5. Pusher Return Spring	VS750375x1.0	4
6. Pusher O-ring	VO-243	1
7. Sleeve	J550	1
8. Axle	K020	6
9. Small roller	K025	12
10. Large roller	K030	6
11. Ramp	J540	1
12. Piston I.D. O-ring	VO-243	1
13. Piston O.D. Quad Seal	VOQ4267	1
14. 1/4 NPT Socket Pipe Plug	VF0045	1 / 2
15. 1/4 x 1 Shoulder bolt	VT25-00SB1.0	6
16. Washer	J193	6
17. Gland Return Spring	VS500374x1.0	6
18. 10-24 x 3/8 SHC Screw	VT10-24SH375	1
19. Faceplate	J580	1
20. Indicator Pin Guide	J182	2
21. Indicator Pin Spring	VS375250x1.5	2
22. Indicator Pin	J584	2
23. Main Spring - Blue	VS1.0500x3.5	16
24. Piston	J530	1
25. Metric: M16 x 65 mm SHC Screw	VTM16-SH65	6
Standard: 5/8-11 x 2.5 SHC Screw	VT62-11SH2.5	6
26. Chuck Body	J520 / J526	1 / 1
27. 3/8-24x1/2 Socket Set Screw	VT37-24SS500	4
28. Body I.D. O-Ring	VO-243	1
29. Labyrinth Ring	J510 / J511	1 / 1
30. 1/4-20 x 1/2 Flat Socket Head	VT25-20FS500	3 / 4
31. Puller	J560	1
32. Gland	J595	1
33. Gland O.D. O-Ring	VO-177	1
34. Gland I.D. O-Ring	VO-172	1
35. Gland Housing	J600	1
36. 3/8-16x3/8 Socket Set Screw	VT37-16SS375	4
O-Ring / Spare Parts Kit	FB10-32BKIT	1
Rebuild Kit	FB1032BRBLD	1

WRENCHES FOR THE COLLET AND CLAMPS

Collet Pad Clamp Wrench	PSPLINE-C	1
Spanner Wrench	VM3125	1

MAINTENANCE INSTRUCTIONS

In order to maintain accuracy and minimize wear on internal components of the chuck, periodic service is required. This procedure should be performed every six (6) months or 50,000 parts, whichever occurs first. Follow the steps below to keep your chuck operating as efficiently as possible. Refer to the “INSTALLATION” instructions of the manual for further details if needed.

⚠ WARNING TO AVOID PERSONAL INJURY AND MACHINE DAMAGE, WEAR SAFETY GLASSES AND FOLLOW GOOD SHOP SAFETY PRACTICES WHILE PERFORMING ANY MAINTENANCE ON THE CHUCK.

1. Remove the collet from the chuck. Clean chips, coolant and oil from all visible surfaces.

⚠ DANGER TURN OFF THE MAIN POWER TO THE MACHINE BEFORE BEGINNING THE INSTALLATION PROCEDURE TO AVOID MACHINE DAMAGE AND PERSONAL INJURY!

2. Remove all but two socket head cap screws opposite each other from the faceplate. Remove remaining screws two turns at a time to prevent the faceplate from wedging in the chuck body. Refer to the “INSTALLATION” instructions of this manual for more detail.

3. Remove the faceplate and the pusher assembly.

⚠ CAUTION KEEP THIS ASSEMBLY TOGETHER TO PREVENT MACHINE DAMAGE AND PERSONAL INJURY. IF THE TWO PARTS ARE SEPARATED, USE GREAT CARE IN THE REASSEMBLY. SLOWLY AND CAREFULLY INSERT THE PUSHER INTO THE FACEPLATE.

⚠ CAUTION DO NOT WEDGE, AS THE PARTS CAN BE PERMANENTLY DAMAGED AND WILL NOT FUNCTION! CLEAN AS NECESSARY FOR REASSEMBLY.

4. Remove the springs, clean, and inspect for any visible damage. Replace any springs that are damaged with factory authorized parts.
5. Remove the roller and axle assemblies. Inspect for excessive wear and/or cracks on the rollers and replace as necessary with factory authorized parts.
6. Remove the ramp and piston together by threading two ¼-20 bolts through the aluminum handle and into the threaded holes in the piston and pull both out together. Remove the bolts after the piston and ramp are out of the chuck body.



WARNING

PRODUCTION DYNAMICS RECOMMENDS LUBRIPLATE No. 1444 GREASE, PRODUCTION DYNAMICS PART No. VM0012. FAILURE TO USE THIS LUBRICATION MAY CAUSE EXCESSIVE WEAR TO MOVING COMPONENTS AND/OR RESULT IN CHUCK FAILURE.

7. Clean and inspect the inside contour portion of the piston for excessive wear. Replace the piston if necessary. Replace both o-rings, if necessary, with factory authorized parts, and apply a light coat of grease to each.
8. Remove the chuck body from the spindle by removing the six socket head cap screws. Clean body. Clean and inspect the puller that is in the rear counterbore of the body.
9. To remove the gland, remove the shoulder bolts and springs in the gland face. Screw two 10-32 screws through the handle provided and into the threaded holes in the gland. Pull gland straight out with a firm pull. Clean gland and replace o-rings, with factory authorized parts if necessary. Grease o-rings lightly.
10. Clean the gland housing. Inspect inside of housing where gland o-rings ride for any chips or burrs. O-ring surfaces must be smooth. Lightly grease o-ring surfaces before installing gland.

From this point refer to the “**INSTALLATION**” instructions of this manual for the installation of the chuck and follow the same procedure.

11. Open and close the chuck, to assure proper operation. Install the collet and with a piece of bar stock in the chuck; tighten collet to desired clamping force.
12. Adjust the concentricity of the faceplate and tighten the socket head cap screws in the faceplate.

PROCEDURE TO DISASSEMBLE THE CHUCK WITH THE COLLET GRIPPED ON THE WORKPIECE

1. **TURN AIR OFF TO MACHINE!** To prevent damage to the machine and/or personal injury.
2. Remove two of the faceplate bolts that are opposite each other. Install bolts that are 3/8" longer into these holes. Remove the remaining faceplate bolts, per the procedure in the front part of this manual. Begin loosening the two remaining longer bolts. Alternate between the two until all spring tension is removed. The longer bolts prevent the faceplate from coming off under spring tension.
3. Remove the faceplate. The pusher and collet will remain on the chuck.
4. Remove the springs and indicator pins from the piston.
5. With a soft blow hammer, GENTLY begin tapping the pusher back. This should push the rollers back into the piston, which will allow the collet to open.
6. Remove workpiece. Remove collet, being careful not to drop the pusher when the collet is completely removed.
7. Remove the ramp, rollers, and piston, as described earlier in the manual.
8. Remove the chuck body.
9. Replace O-rings as needed and perform maintenance on the gland and gland housing.
10. Reassemble the chuck



TO PREVENT PERSONAL INJURY AND MACHINE DAMAGE, BE CAREFUL WHEN INSTALLING THE PUSHER IN THE FACEPLATE. GREASE BOTH ITEMS BEFORE INSTALLING THE PUSHER IN THE FACEPLATE.



TO PREVENT MACHINE DAMAGE AND PERSONAL INJURY, BE CAREFUL TO USE THE SAME LENGTH BOLTS WHEN REINSTALLING THE FACEPLATE.

11. Install collet. Set concentricity. Set grip force.

TROUBLE SHOOTING GUIDE

The following procedures should be performed should the chuck not function properly. If the following procedures fail to take care of the problem with the chuck, please call **Production Dynamics** at 800-445-1196 to answer your questions.

⚠ CAUTION IN ALL CASES, UNLESS OTHERWISE SPECIFIED, TURN AIR AND ELECTRICAL POWER OFF TO THE MACHINE UNTIL RE-ASSEMBLY IS COMPLETE TO PREVENT MACHINE DAMAGE AND PERSONAL INJURY.

SYMPTOM	CAUSE	SOLUTION
Chuck not opening, Indicator pins not moving	Air supply	½" I.D. air line must be capable of supplying 100 psi air while flowing a sufficient volume of 20 CFM.
Chuck not opening, indicator pins not moving, air leak between chuck and gland housing.	Gland leaking due to cut-o-ring in gland.	Remove chuck from spindle and remove gland from housing.
	Gland sealing face worn out.	Replace o-ring and/or gland. Reassemble Chuck and test. Refer to maintenance portion of this manual for this procedure.
Chuck not opening, air leaking from indicator pin holes.	Cut o-ring on piston	Remove collet, faceplate, springs, rollers, ramp, and piston. Replace o.d. o-ring and/or i.d. o-ring.
Chuck not opening, indicator pins moving.	Chips inside chuck, preventing chuck from opening.	Disassemble the chuck. Clean, grease lightly, and reassemble.
	Pusher stuck to collet	With chuck in open position, gently tap on pusher until pusher moves back. Grease collet and pusher tapers.
	Rollers in chuck not rolling back to allow pusher to release collet.	Remove collet, faceplate, springs and rollers. Clean and inspect rollers. Apply a small amount of grease to roller assemblies, and reassemble.
	Concentricity set screws to tight.	Back off set screws to snug after faceplate cap screws are tight
	Check indicator pin travel.	Low air pressure.

SYMPTOM	CAUSE	SOLUTION
Chuck not opening, indicator pins not moving.	Broken rollers.	Remove collet, faceplate, springs and rollers. Replace all rollers, grease each assembly lightly, and reassemble the chuck.
Stock being pushed back into chuck.	Improperly adjusted collet.	Readjust clamp force. In chucked position, indicator pins should be flush with counterbores in faceplate.
	Check grip force springs.	Replace broken Springs.
	Smooth pads	Try serrated pads.
Stock being crushed by collet.	Improperly adjusted collet.	Reduce clamp force on workpiece. Indicator pins will sit less than flush with faceplate. Clamp force can also be reduced by removing a number of main springs. (Item 23 on parts list). Remove 2 springs at a time, opposite each other. Reassemble the chuck and adjust the clamping force. Always leave a minimum of four springs at 90°, two of these having the indicator pin assemblies.
Chuck is getting hot	Chuck body rubbing Gland Housing	Adjust set screws on the gland housing to center housing on the bearing cap.



2025 Mercer Road, Lexington, Kentucky 40511
859-255-5001 • 800-445-1196 • Fax 859-255-6656
www.lexairinc.com